

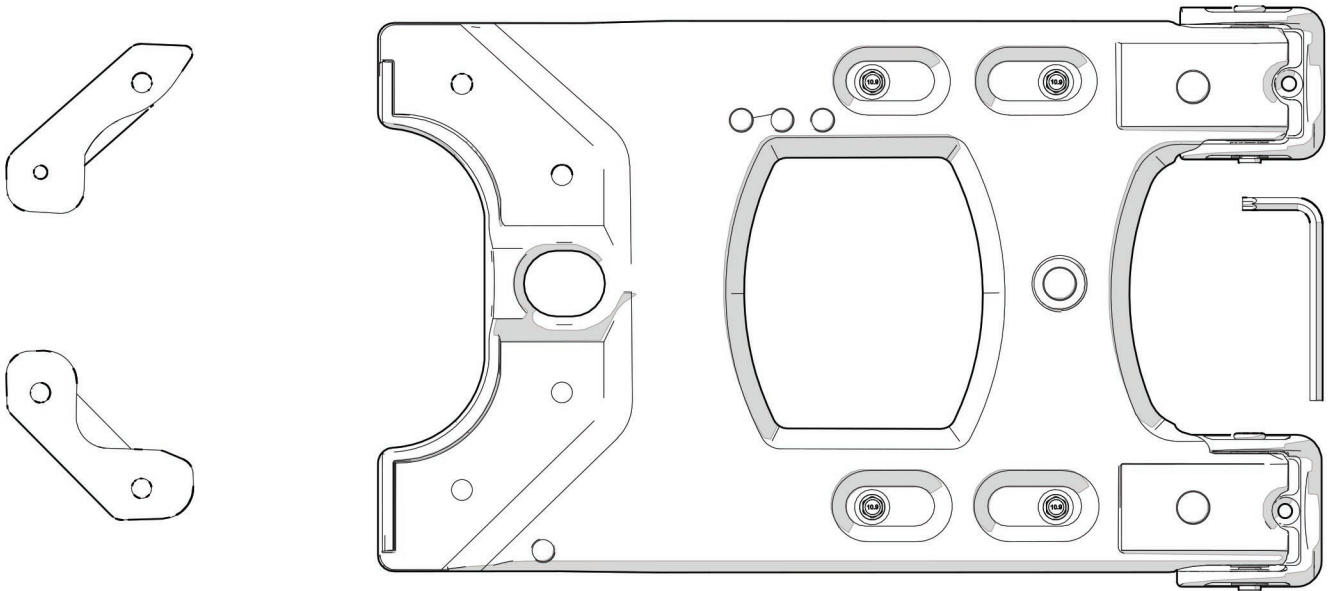

HINGE TAILGATE TIRE CARRIER

www.BLKMTNJeep.com

#BMTGTC



Important Notes:

Prior to beginning this or any installation read these instructions to familiarize yourself with the required steps and evaluate if you are experienced and capable to personally perform these modifications. A factory service manual should be used in conjunction with these installation instructions.

Refer to the parts list to ensure that all necessary components and hardware has been included. If any parts are missing please contact your local Black Mountain for assistance.

Tools needed:

- Lug Wrench
- T50 Torx driver (included)
- T20 Torx driver
- 13 mm socket
- 12 mm socket
- Ratchet
- Blue thread locking compound
- Spacer that will fit between your Jeep's bumper and the bottom of the tail gate (soft material such as wood is recommended to avoid damaging the vehicle's paint)

IMPORTANT: Do not remove the factory tailgate hinges until instructed to do so. Precisely following these instructions will help avoid any tailgate adjustment and misalignment issues. Ensure the tailgate is closed tightly and do not open it during installation.

1

2



T20 Torx



3

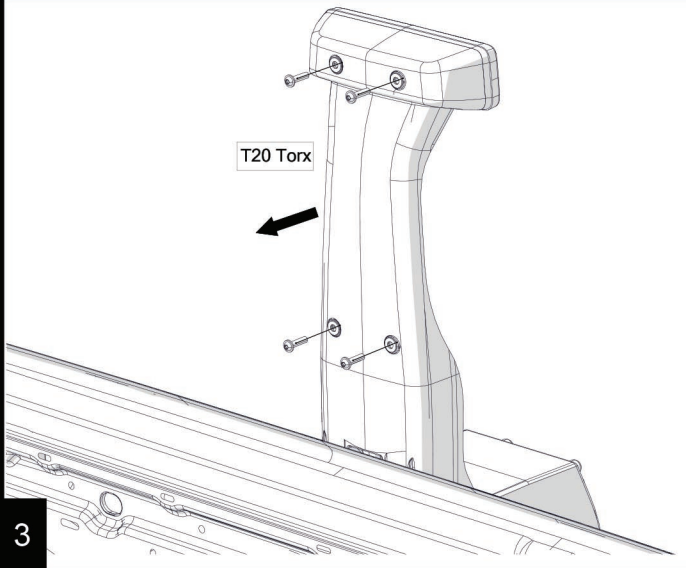

Unplug light connector

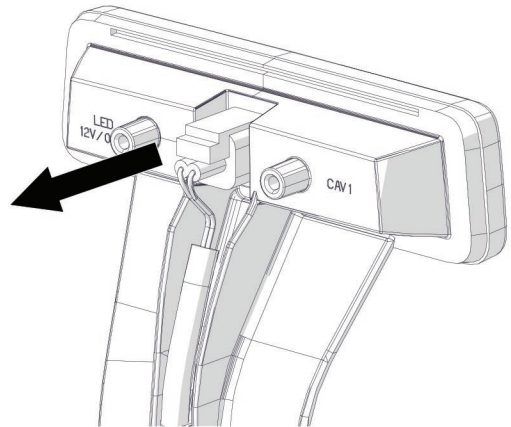

4

Remove tire mount

13 mm 8x



5

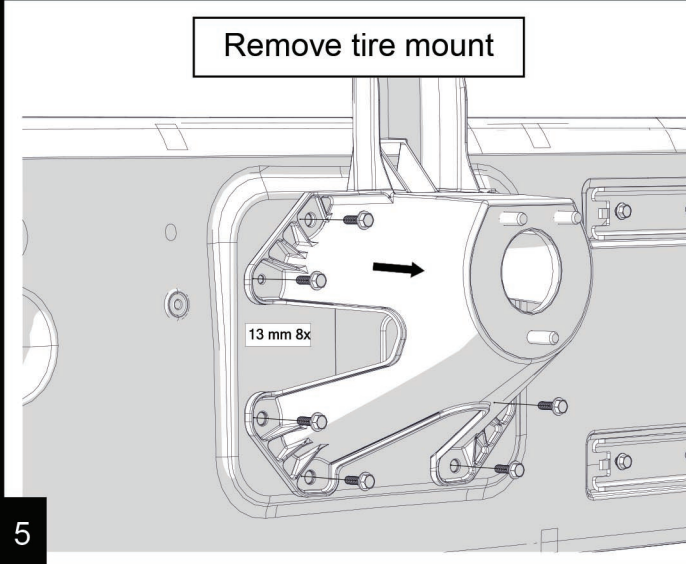

Place spacer under tailgate to support after hinge removal

6

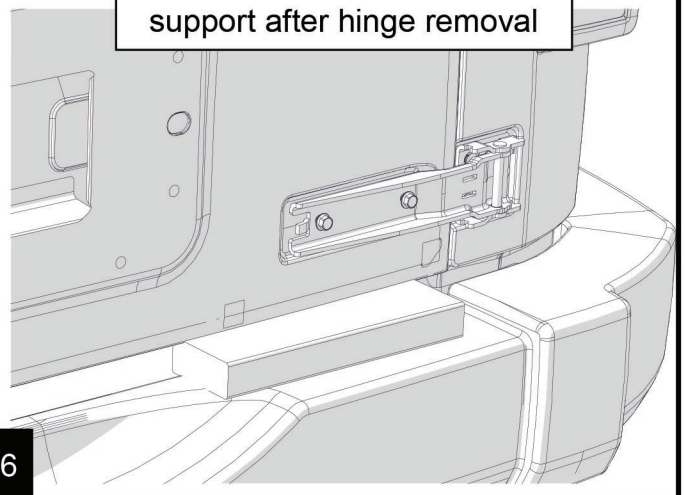

Apply thread locking compound, loosely seat original bolts into the hinges

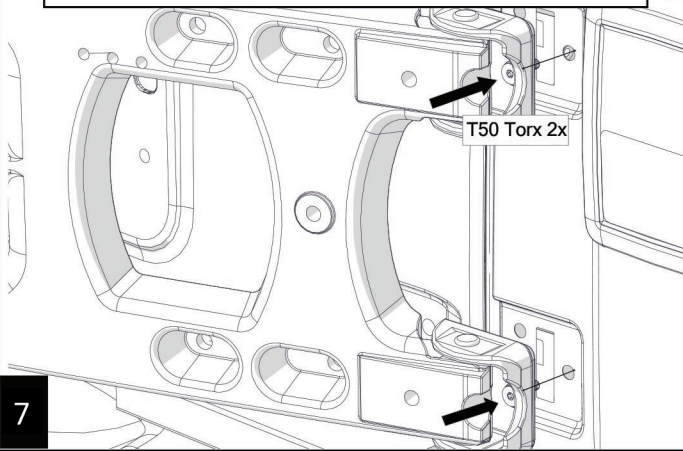

7

Install bolt to align cast hinge to tailgate. Visually inspect all bolt holes for alignment

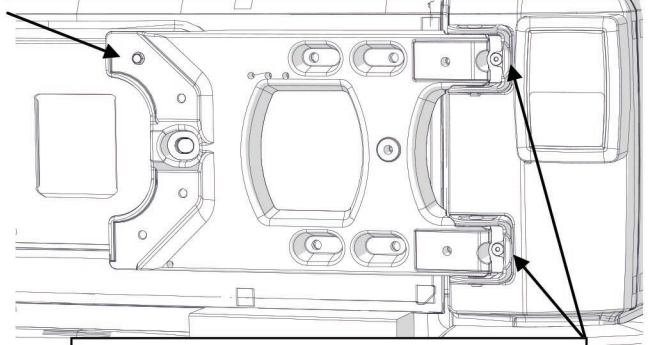

8

After alignment is complete, torque bolts to 26 N-m (19 ft-lbs)

Open hinge, apply thread locking compound, torque bolts to 26 N-m (19 ft-lbs)

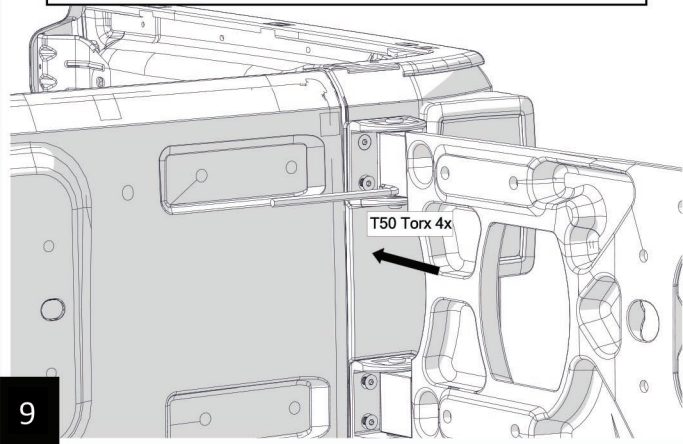

9

Apply thread locking compound, install and torque included bolts to 20 N-m (15 ft-lbs)

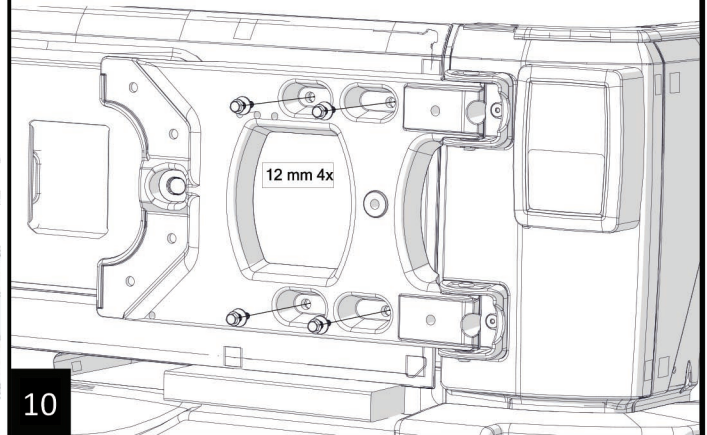

10

This completes install for Hinge Carrier, move on to Step 12 for install of the Tire Mount

11

Reuse original hardware, apply thread locking compound and loosely install bolts

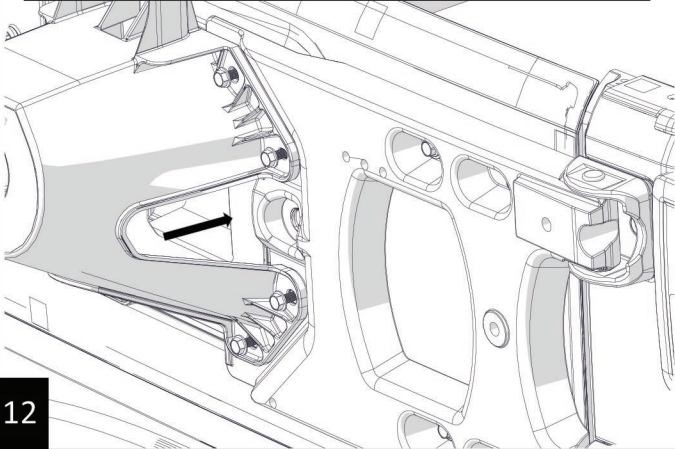

12

Place gaskets between cast hinge and mount, apply thread locking compound and loosely install remaining 4 original bolts

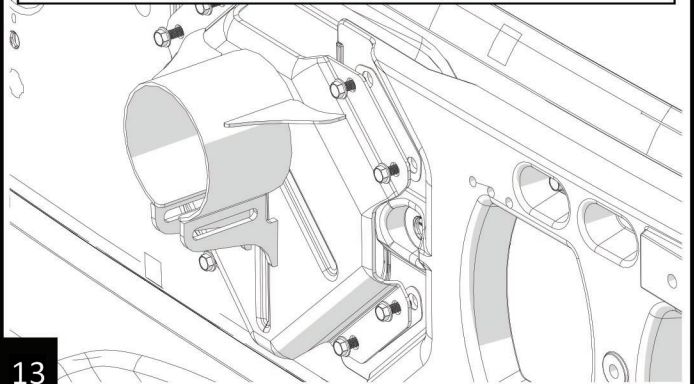

13

Torque the 8 mounting bolts to 20 N-m (15 ft-lbs)

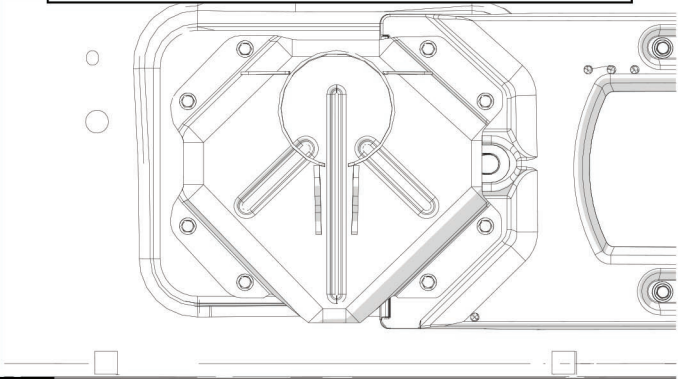

14

Press the 3 included wheel studs into the appropriate set of holes for your tire size

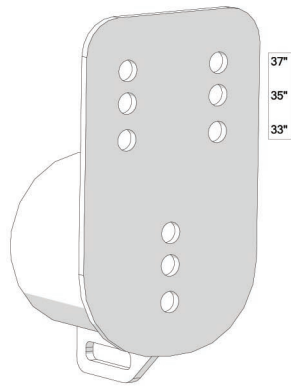

15

Attach the mount to the tire using 1 lug nut

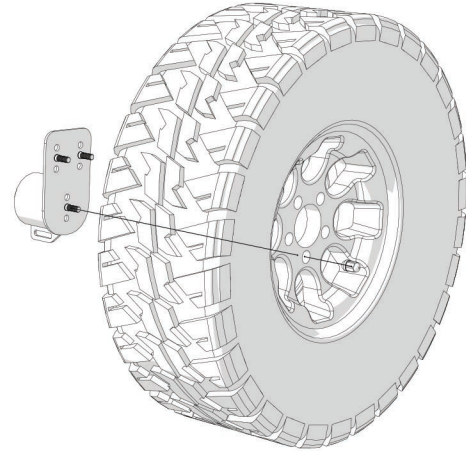

16

Slide the mount into the base on the tailgate, push the tire firmly up against the cast hinge

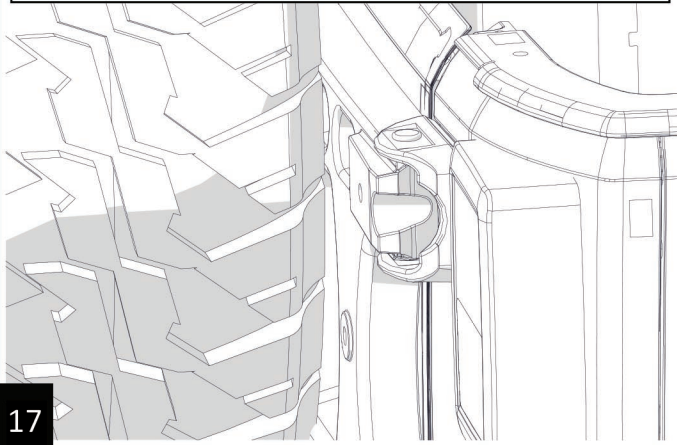

17

Mark a line on the mount where it meets the base, remove spare tire and mount assembly

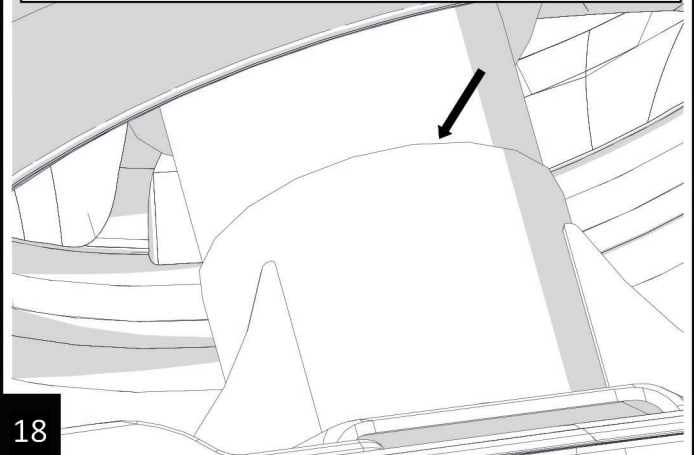

18

Remove the mount from the tire, using marked line as a reference, push mount in 1/8" - 3/16" (3 - 4 mm) past line

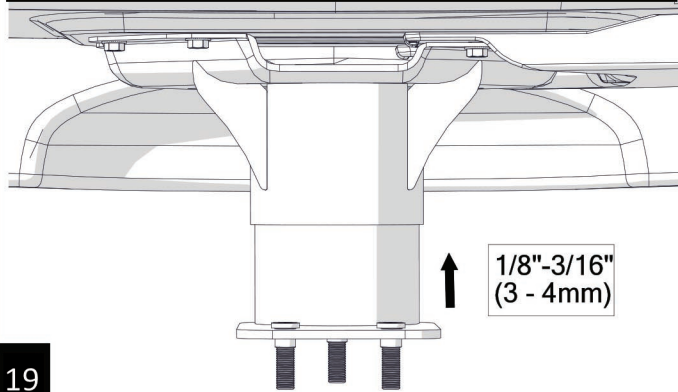

19

Install pinch bolts and spacers. Ensure at least 1 bolt is installed through slot on mount. Torque bolts to 51 N-m (38 ft-lbs)

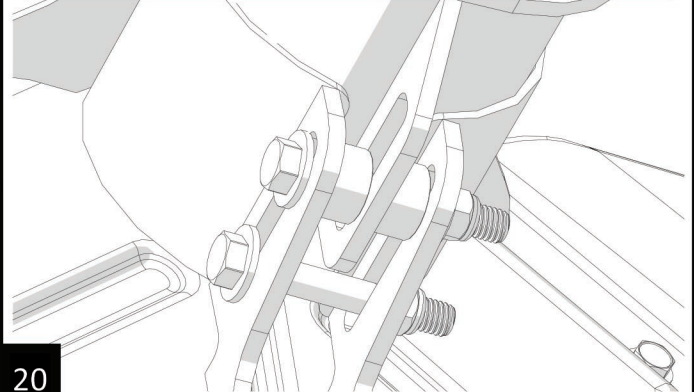

20

Cut factory third brake light along black line

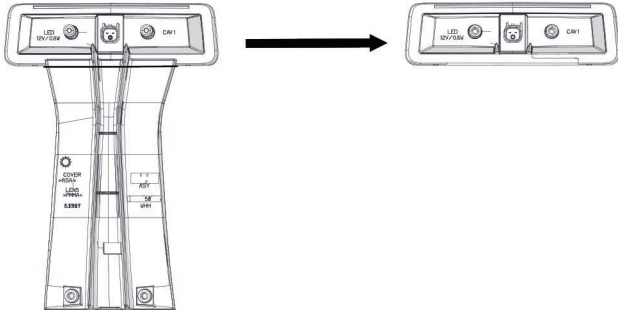

21

Use 2 original T20 Torx screws to mount the cut third brake light to bracket

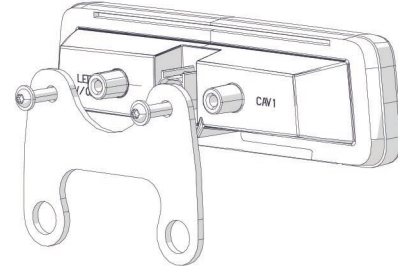

22

Install spare tire using the two lug nuts included in the kit and one original, torque to 87 N-m (65 ft-lbs)

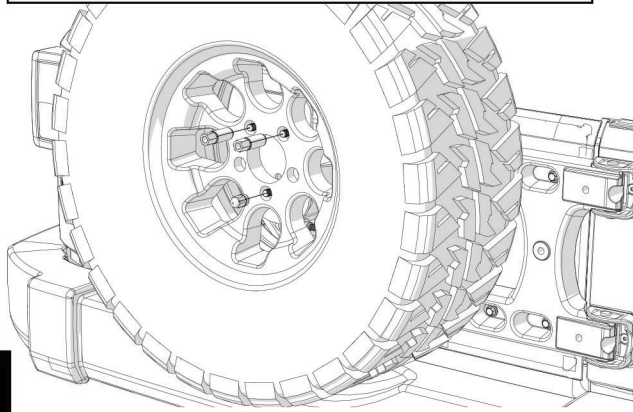

23

Route brake light wiring through wheel, plug light in and torque bolts to 50 N-m (37 ft-lbs)

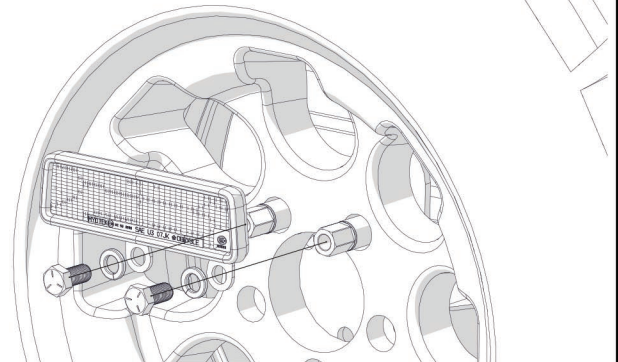

24

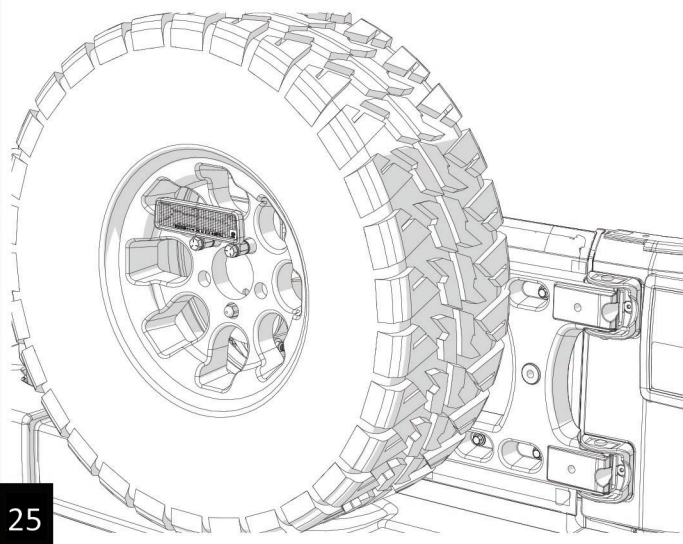

25

- Open and close tailgate to ensure proper function if cast hinge was installed.
- Ensure tire is **firmly** pressed against the cast hinge or against the factory tire bumpers on the tailgate if the cast hinge was not used
- Fold and place this instruction sheet in the vehicle glove box for future reference.
- For further questions/concerns contact your Black Mountain Dealer

26